



CASH VALVE TYPE G-60 1/4" TO 1 1/2" FOR CRYOGENIC SERVICE INSTALLATION, OPERATION AND MAINTENANCE INSTRUCTIONS

Before installation, these instructions must be carefully read and understood.



DESCRIPTION

The Type G-60 regulator is a fully automatic pressure regulating valve designed for cryogenic service in the pressure build-up circuit. Because it may be used for either cryogenic liquids or gases, it may be installed either before or after the pressure build-up coil.

SPECIFICATION DATA

Service: Cryogenic liquids and gases (pressure reducing or pressure build-up service).

Sizes: 1/4" to 1 1/2"

Connections: NPT threads internal inlet and outlet.

Body Material: Bronze or Stainless Steel.

Temperature Rating: +150°F (65°C) to -320°F (-195°C)

Maximum Initial Pressure: 600 psi (41.4 bar)

INSTALLATION INSTRUCTIONS

The Type G-60 regulator should be installed in the horizontal position with the spring chamber upright. For other installation requirements consult the factory. For ease of operation and maintenance, it is suggested that manual shut-off valves be installed upstream and downstream from the valve. Before installing the valve, the piping and valve should be thoroughly flushed out to remove any foreign material. Install the valve with the inlet pipe fitted to the inlet connection identified on the

valve body. Use a compatible sealant on the male pipe threads and do not over tighten the valve connections.

CONSTRUCTION

See component description for materials of construction.

All parts commercially cleaned for oxygen service.

OPERATING INSTRUCTIONS

Adjusting the Delivery Pressure:

The regulator's delivery pressure setting is adjusted by turning the adjusting screw [2] (after removing optional cap [1]) at the top of the spring chamber [5] after loosening the adjusting screw lock nut [3]. To increase the delivery pressure, turn the adjusting screw clockwise (into the spring chamber). To decrease the delivery pressure, turn the adjusting screw counter-clockwise (out of the spring chamber). Tighten the adjusting screw lock nut after the adjustment has been made (and reinstall optional cap).

MAINTENANCE INSTRUCTIONS

CAUTION

Before attempting to replace any spare parts, be sure to shut off all pressure connections to the valve. With the valve closed however, system pressure could still be locked between the shut off valve and the inlet and/or outlet sides of the regulator. Before proceeding with any valve service, be certain to relieve the pressure from both sides of the regulator.

Refer to section view for parts identification. Repair parts can easily be installed without removing the regulator from the line.

Servicing Diaphragm(s) and Pressure Spring

1. Loosen the lock nut and turn the adjusting screw counterclockwise until the pressure spring is no longer under tension. When reassembling, run the adjusting screw down until the lock nut almost touches the spring

chamber. This will give you approximately the same set as before disassembly.

2. Remove the assembly screws securing the spring chamber to the body. During reassembly, tighten the screws evenly in a star pattern.
3. Remove the spring chamber. Then remove the spring button, pressure spring, and pressure plate.
4. Remove the diaphragm(s) and diaphragm gasket (a diaphragm gasket is only present when construction calls for metal diaphragms)
5. Remove the pusher post button. During reassembly, ensure the pusher post button is centered properly on the pusher post.
6. Inspect all parts for wear and damage and replace if necessary. Reassemble parts in reverse order. DO NOT OVERTIGHTEN. Follow the Operation Instructions to reset the delivery pressure.

Servicing the Piston, Seat Ring and Plug Gasket

1. Loosen the lock nut and turn the adjusting screw counterclockwise until the pressure spring is no longer under tension. When reassembling, run the adjusting screw down until the lock nut almost touches the spring chamber. This will give you approximately the same set as before disassembly.
2. Remove the bottom plug. Take care, as the bottom plug is under slight tension as a result of the piston spring acting against the bottom plug. During reassembly, tighten the screws evenly in a star pattern.
3. Remove the piston and piston spring.
4. Flush the valve body to remove any debris.
5. Remove the hexagon seat ring. When reassembling, torque the seat ring to 350 in-lbs.
6. Inspect all parts for wear and damage. If either the seat ring or piston need replacing, it is necessary to replace both as both parts wear equally.
7. Reassemble the valve in reverse order. DO NOT OVERTIGHTEN. Follow the Operation Instructions to reset the delivery pressure.

CASH VALVE TYPE G-60 1/4" TO 1 1/2" FOR CRYOGENIC SERVICE

INSTALLATION, OPERATION AND MAINTENANCE INSTRUCTIONS

No.	Component Description	Construction
1	Adjusting Screw Cap (Optional)	Brass
2	Adjusting Screw	SST
3	Lock Nut	SST
4	Gasket (Optional)	Polypropylene
5	Spring Chamber	Bronze or SST
6	Spring Button	Brass
7	Pressure Spring	SST
8	Nameplate	Aluminum
9	Drive Screw	SST
10	Pressure Plate	Bronze
11	Screw	SST
12	Diaphragm	SST, Bronze or Buna-N (w/ Teflon Liner)
13	Gasket	Teflon
14	Pusher Post Button	SST or Brass
15	Guide Bushing	SST
16	Pusher Post	SST or Brass
17	Seat Ring	SST
18	Seat Disc	Teflon, Viton or Kel-F
19	Piston	SST or Brass
20	Body	SST or Bronze
21	Gasket	Teflon
22	Piston Spring	SST
23	Bottom Plug	SST or Bronze

FIGURE 1

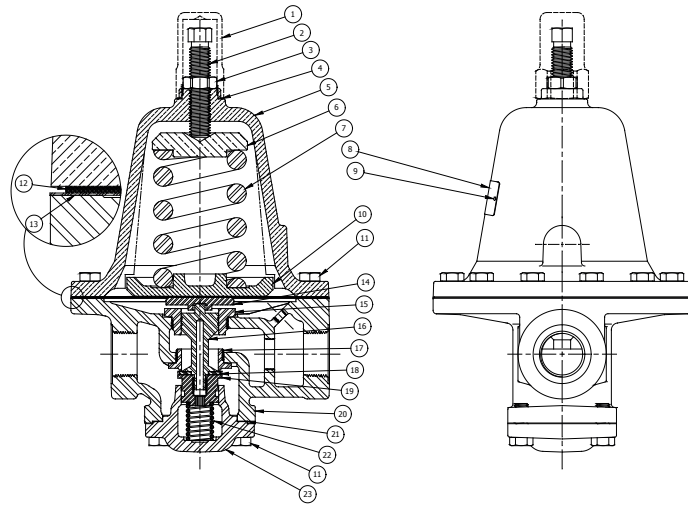

D104628X012 © 2019, 2020 Emerson Electric Co. All rights reserved 04/20. Cash Valve is a mark owned by one of the companies in the Emerson Automation Solutions business unit of Emerson Electric Co. The Emerson logo is a trademark and service mark of Emerson Electric Co. All other marks are the property of their prospective owners.

The contents of this publication are presented for informational purposes only, and while every effort has been made to ensure their accuracy, they are not to be construed as warranties or guarantees, express or implied, regarding the products or services described herein or their use or applicability. All sales are governed by our terms and conditions, which are available upon request. We reserve the right to modify or improve the designs or specifications of such products at any time without notice.

Emerson Electric Co. does not assume responsibility for the selection, use or maintenance of any product. Responsibility for proper selection, use and maintenance of any Emerson Electric Co. product remains solely with the purchaser.

Emerson.com/FinalControl